

# **XP-AC-SL Series**

Pulse-Width Modulated,  
Adjustable Speed Drives  
for DC Brush Motors

## **Models:**

**XP01-115AC-E10U**

**XP01-115AC-SL**

**XP03-115AC-SL**



**User's Manual**

Copyright © 2001 by  
Minarik Corporation

All rights reserved. No part of this manual may be reproduced or transmitted in any form without written permission from Minarik Corporation. The information and technical data in this manual are subject to change without notice. Minarik Corporation and its Divisions make no warranty of any kind with respect to this material, including, but not limited to, the implied warranties of its merchantability and fitness for a given purpose. Minarik Corporation and its Divisions assume no responsibility for any errors that may appear in this manual and make no commitment to update or to keep current the information in this manual.

Printed in the United States of America.

---

## Safety Warnings



**Note:** This symbol  denotes an important safety message. Please read these sections carefully before performing any instructions contained in this manual.

- Have a qualified electrical maintenance technician install, adjust and service this equipment. Follow the National Electrical Code and all other applicable electrical and safety codes, including the provisions of the Occupational Safety and Health Act (OSHA), when installing equipment.
- Reduce the chance of an electrical fire, shock, or explosion by proper grounding, over current protection, thermal protection, and enclosure. Follow sound maintenance procedures.

---

## Table of Contents

<b>Specifications</b>	<b>1</b>
<b>Dimensions</b>	<b>2</b>
<b>Installation</b>	<b>4</b>
Mounting	4
Wiring	5
Shielding guidelines	6
Line fusing	7
Speed adjust potentiometer	7
<b>Connections</b>	<b>9</b>
XP-AC-SL series connections	9
Motor	9
Power input	10
Line fuse	10
XP-AC-E10U series connections	12
Motor	12
Power input	12
Line fuse	13
Voltage follower configuration	14
<b>Operation</b>	<b>16</b>
Before applying power	16
Startup	16
Starting and Stopping Methods	17
Automatic restart upon power restoration	18

---

Line starting and line stopping	18
Decelerating to minimum speed	18
Dynamic braking	18
<b>Calibration</b>	<b>21</b>
MAXIMUM SPEED (MAX SPD)	24
MINIMUM SPEED (MIN)	24
TORQUE (TQ)	25
IR COMP	26
<b>Application Notes</b>	<b>28</b>
Multiple fixed speeds	28
Adjustable speeds using potentiometers in series	29
Independent adjustable speeds	30
RUN/JOG switch	31
Connection to other Minarik devices	32
Leader-follower application	33
Single speed potentiometer control of multiple drives	34
Reversing	36
Reversing with a DIGI-LOK® controller	36
<b>Troubleshooting</b>	<b>39</b>
Before troubleshooting	39
Block Diagrams	42
Replacement Parts	44
<b>Unconditional Warranty</b>	<b>inside back cover</b>

---

## Illustrations

Figure 1. XP-AC-SL Series Dimensions	2
Figure 2. XP-AC-E10U Series Dimensions	3
Figure 3. Speed Adjust Potentiometer	8
Figure 4. XP-AC-SL Series Connections	11
Figure 5. XP-115AC-E10U Series Connections	13
Figure 6. XP-AC-SL Voltage Follower Connections	14
Figure 7. XP-115AC-E10U Voltage Follower Connections	15
Figure 8. Decelerate to Minimum Speed	19
Figure 9. Dynamic Brake Connection	20
Figure 10. XP-AC-SL Calibration Trimpot Layout	22
Figure 11. XP-AC-E10U Calibration Trimpot Layout	23
Figure 12. Recommended Torque and IR COMP Settings	27
Figure 13. Multiple Fixed Speeds	28
Figure 14. Adjustable Fixed Speeds Using Potentiometers in Series	29
Figure 15. Independent Adjustable Speeds	30
Figure 16. RUN/JOG Switch Connection to Speed Adjust Potentiometer	31
Figure 17. Connecting an XP-AC Series Drive to a PCM4 or DLC600	32
Figure 18. Leader-Follower Application	33
Figure 19. Single Speed Potentiometer Control of Multiple Drives	34
Figure 20. PCM4 Speed Ratio Application	35
Figure 21. Reversing Circuit Connections	37
Figure 22. Reversing with a DLC600	38
Figure 23. XP-AC Series Block Diagram	42
Figure 24. XP-AC Series Input Circuit Diagram	43

## Specifications

<b>Model</b>	<b>Max. Continuous Armature Current (DC Amps)</b>	<b>HP Range with 115 VAC Applied</b>
XP01-115AC-E10U	1	1/100 – 1/25
XP01-115AC-SL	1	1/100 – 1/25
XP03-115AC-SL	3	1/20 – 1/4

  

<b>AC Line Voltage</b>	115 VAC $\pm$ 10%, 50/60 Hz, single phase
<b>Armature Voltage Range</b>	0–130 VDC
<b>Form Factor (at base speed)</b>	1.05
<b>Acceleration/Deceleration Time Range (no load)</b>	1 second
<b>Analog Input Voltage Range (signal must be isolated)</b>	0 – 5 VDC
<b>Input Impedance (S1 to S2)</b>	approximately 150K ohms
<b>Speed Regulation</b>	1% base speed or better
<b>Ambient Temp. Range (chassis drive)</b>	10°C–55°C
<b>Weight</b>	0.3 lb

## Dimensions

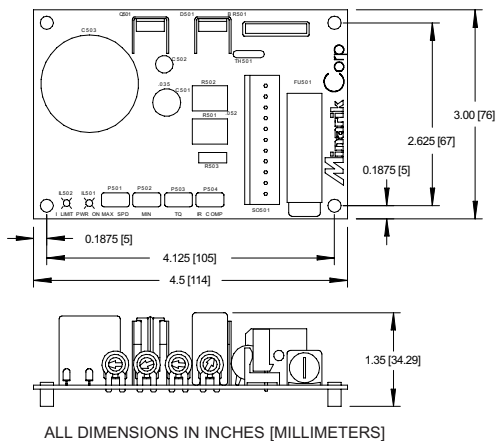

**Figure 1. XP-AC-SL Series Dimensions**

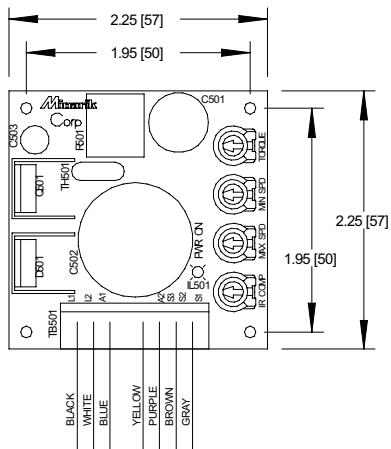

ALL DIMENSIONS IN INCHES [MILLIMETERS]

**Figure 2. XP-AC-E10U Series Dimensions**

---

## Installation



### Warning

Do not install, rewire, or remove this control with input power applied. Doing so may cause fire or serious injury. Make sure you have read and understood the Safety Warnings on page i before attempting installation.

The chassis must be earth grounded. Use a star washer beneath the head of at least one of the mounting screws to penetrate the anodized chassis surface and to reach bare metal.

## Mounting

- Drive components are sensitive to electrostatic fields. Avoid contact with the circuit board directly. Hold drive by the chassis only.
- Protect the drive from dirt, moisture, and accidental contact.
- Provide sufficient room for access to the terminal block and calibration trimpots.
- Mount the drive away from heat sources. Operate the drive within the specified ambient operating temperature range.
- Prevent loose connections by avoiding excessive vibration of the drive.
- Mount drive with its board in either a horizontal or vertical plane. Six 0.19 in. (5 mm) wide slots in the chassis accept #8 pan head screws. Fasten either the large base or the narrow flange of the chassis to the subplate.

## Wiring



### Warning

Do not install, remove, or rewire this equipment with power applied. Failure to heed this warning may result in fire, explosion, or serious injury.

Circuit potentials are at 115 or 230 VAC above ground. To prevent the risk of injury or fatality, avoid direct contact with the printed circuit board or with circuit elements.

Do not disconnect any of the motor leads from the drive unless power is removed and the drive is disabled. Opening any one motor lead may destroy the drive.

- Use 18-24 AWG wire for speed adjust potentiometer wiring. Use 14–16 AWG wire for AC line (L1, L2) and motor (A1 and A2) wiring.

## Shielding guidelines

**Warning**

Under no circumstances should power and logic leads be bundled together. Induced voltage can cause unpredictable behavior in any electronic device, including motor controls.

As a general rule, Minarik recommends shielding of all conductors.

If it is not practical to shield power conductors, Minarik recommends shielding all logic-level leads. If shielding of logic leads is not practical, the user should twist all logic leads with themselves to minimize induced noise.

It may be necessary to earth ground the shielded cable. If noise is produced by devices other than the drive, ground the shield at the drive end. If noise is generated by a device on the drive, ground the shield at the end away from the drive. Do not ground both ends of the shield.

If the drive continues to pick up noise after grounding the shield, it may be necessary to add AC line filtering devices, or to mount the drive in a less noisy environment.

Logic wires from other input devices, such as motion controllers and PLL velocity controllers, must be separated from power lines in the same manner as the logic I/O on this drive.

---

## Line fusing

Protect all Minarik drives with AC line fuses. For XP03-115AC-SL, use fast acting AC line fuse rated for 8 amps at 250 volts. For all other XP series drives, use fast acting AC line fuse rated for 3 amps at 250 volts. Fuse only the “hot” side of the AC line (L1).

## Speed adjust potentiometer

**Warning**

Be sure that the potentiometer tabs do not make contact with the potentiometer enclosure. Grounding the input will cause damage to the drive.

Mount the speed adjust potentiometer through a 0.38 in. (10 mm) hole with the hardware provided (see Figure 3, page 8). Install the circular insulating disk between the panel and the 10K ohm speed adjust potentiometer.

Twist the speed adjust potentiometer wire to avoid picking up unwanted electrical noise. If speed adjust potentiometer wires are longer than 18 in. (457 mm), use shielded cable. Keep the speed adjust potentiometer wires separate from power leads (L1, L2, A1, A2).

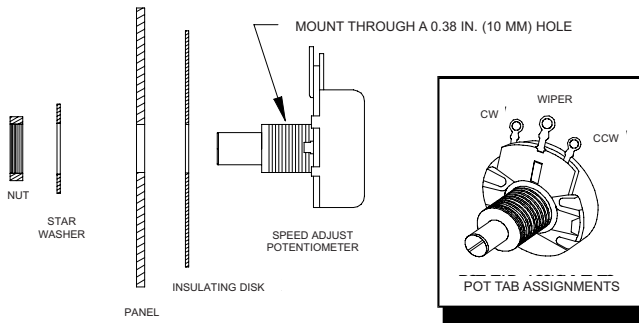

**Figure 3. Speed Adjust Potentiometer**

---

## Connections



Do not connect this equipment with power applied. Failure to heed this directive may result in fire or serious injury.

### **Warning**

Minarik strongly recommends the installation of a master power switch in the voltage input line, as shown in Figure 5 (page 13). The switch contacts should be rated at a minimum of 200% of motor nameplate current and 250 volts.

## XP-AC-SL series connections

Connect the power input leads, an external line fuse and a DC motor as shown in Figure 4 (page 11).

### **Motor**

Minarik drives supply voltage from A1 and A2 terminals. It is assumed throughout this manual that, when A1 is positive with respect to A2, the motor will rotate clockwise (CW) while looking at the output shaft protruding from the front of the motor. If this is opposite of the desired rotation, simply reverse the wiring of A1 and A2 with each other.

Connect a DC motor to terminals A1 and A2 as shown in Figure 4 (page 11). **Ensure that the motor voltage and current ratings are consistent with the drive's output voltage and current.**

## Power input

Connect the AC line power leads to terminals L1 and L2, or to a single-throw, double-pole master power switch (recommended).

## Line fuse

Wire an external line fuse between the stop switch (if installed) and the L1 terminal as shown in Figure 4. The XP03-115-SL line fuse should be rated at 250 volts and 8 amps.

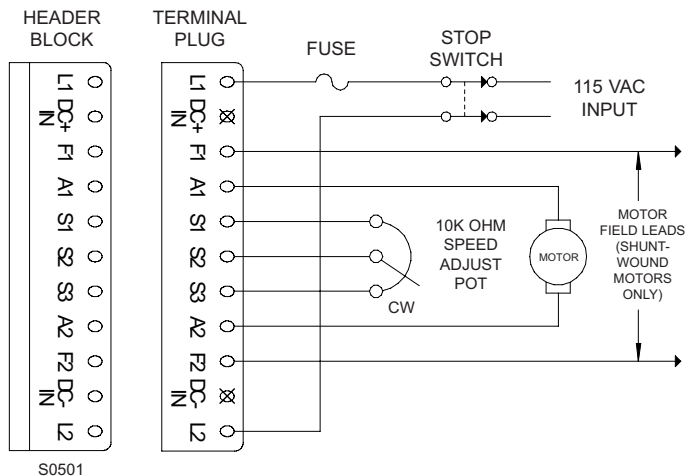

Figure 4. XP-AC-SL Series Connections

## XP-AC-E10U series connections

Connect the power input leads, an external line fuse and a DC motor to terminal board TB501 as shown in Figure 5 (page 13).

### Motor

Minarik drives supply motor voltage from A1 and A2 terminals. It is assumed throughout this manual that, when A1 is positive with respect to A2, the motor will rotate clockwise (CW) while looking at the output shaft protruding from the front of the motor. If this is opposite of the desired rotation, simply reverse the wiring of A1 and A2 with each other.

Connect a DC motor to terminals A1 and A2 as shown in Figure 5 (page 13). **Ensure that the motor voltage and current ratings are consistent with the drive's output voltage and current.**

### Power input

Connect the AC line power leads to terminals L1 and L2, or to a single-throw, double-pole master power switch (recommended).

## Line fuse

Wire an external line fuse between the stop switch (if installed) and the L1 terminal. The line fuse should be rated at 250 volts and 3 amps.

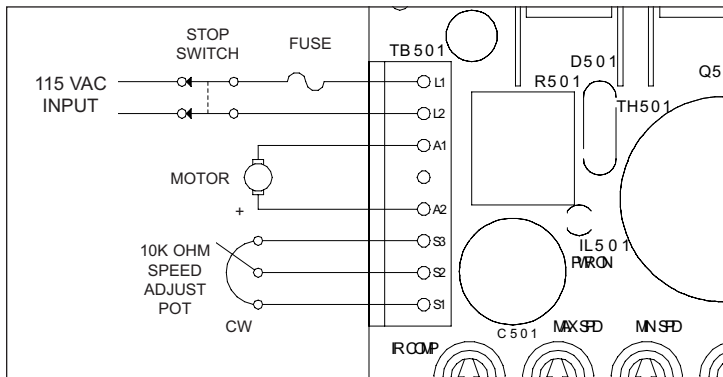

**Figure 5. XP-115AC-E10U Series Connections**

## Voltage follower configuration



### Warning

Do not connect a non-isolated input voltage signal to any XP Series drive. Connecting a non-isolated signal will damage the drive.

Instead of using a speed adjust potentiometer, the drive may be wired to follow a 0–5 VDC voltage signal that is isolated from earth ground (Figure 6 & 7). Connect the signal input (+) to S2. Connect the signal common (–) to S1. Make no connection to S3. A potentiometer can be used to scale the analog input voltage.

To achieve greater linearity and control, use an interface device such as Minarik model PCM4 to scale the analog input voltage. Follow the same wiring guidelines used for speed adjust potentiometer wiring (see page 7 & 8).

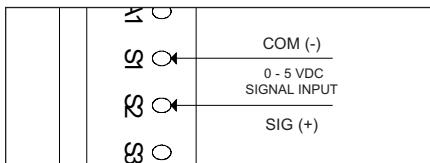

**Figure 6. XP-AC-SL Voltage Follower Connections**

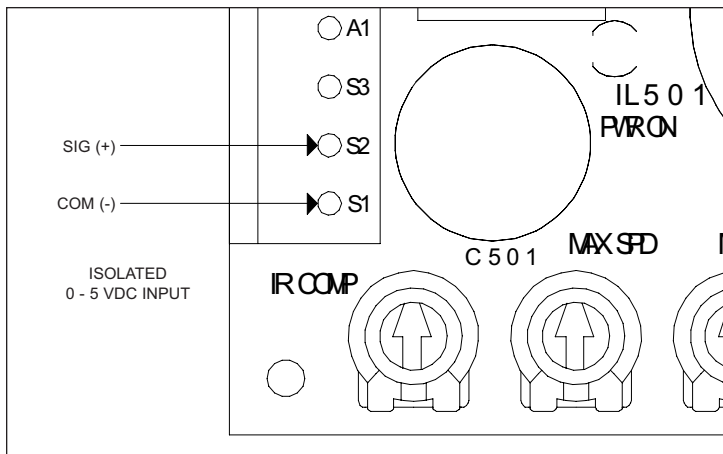

**Figure 7. XP-115AC-E10U Voltage Follower Connections**

## Operation



### Warning

Dangerous voltages exist on the drive when it is powered, and up to 30 seconds after power is removed and the motor stops. BE ALERT. High voltages can cause serious or fatal injury. For your safety, use personal protective equipment (PPE) when operating this drive.

## Before applying power

Verify that no conductive material is present on the printed circuit board.

## Startup

To start the drive:

1. Turn the speed adjust potentiometer full counterclockwise (CCW). If the drive is following a voltage signal, set the voltage signal to 0 VDC.
2. Apply AC line voltage.

3. Slowly advance the speed adjust potentiometer clockwise (CW). If the drive is following a voltage signal, slowly increase the voltage signal. The motor slowly accelerates as the potentiometer is turned CW, or the voltage signal is increased. Continue until the desired speed is reached.
4. Remove AC line voltage from the drive to coast the motor to a stop.

If the motor or drive does not perform as described, disconnect the AC line voltage immediately. Refer to the Troubleshooting section, page 38, for further assistance.

## Starting and Stopping Methods



### Warning

Decelerating to minimum speed or coasting to a stop is recommended for frequent stops. Do not use any of these methods for emergency stopping. They may not stop a drive that is malfunctioning. Removing AC line power (both L1 and L2) is the only acceptable method for emergency stopping.

For this reason, Minarik strongly recommends installing an emergency stop switch on both the L1 and L2 inputs (see Connections, page 9).

## **Automatic restart upon power restoration**

After a one-second time delay, all drives automatically run to set speed when power is applied.

## **Line starting and line stopping**

Line starting and line stopping (applying and removing AC line voltage) is recommended for infrequent starting and stopping of a drive only. When AC line voltage is applied to the drive, the motor accelerates to the speed set by the speed adjust potentiometer. When AC line voltage is removed, the motor coasts to a stop.

## **Decelerating to minimum speed**

Connect the switch as shown in Figure 8 (page 19). Close the switch between S1 and S2 to decelerate the motor from set speed. Open the switch to accelerate the motor to set speed.

## **Dynamic braking**

Dynamic braking may be used to rapidly stop a motor (see Figure 9, page 20). For the RUN/BRAKE switch, use a double pole, double throw switch rated for at least the maximum DC armature voltage and maximum braking current.

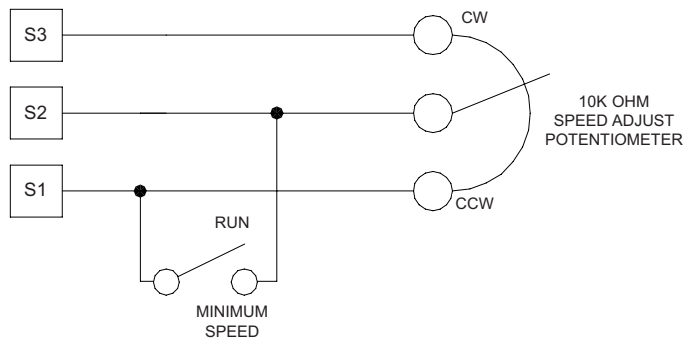

**Figure 8. Decelerate to Minimum Speed**

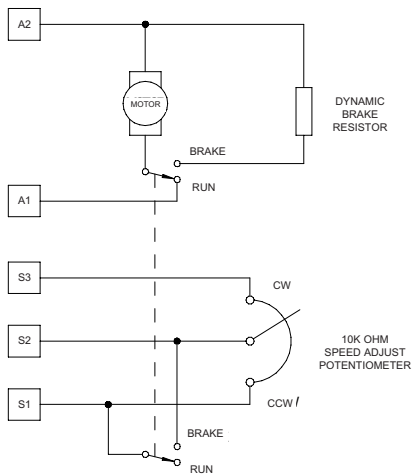

**Figure 9. Dynamic Brake Connection**

---

## Calibration



### Warning

Dangerous voltages exist on the drive when it is powered and up to 30 seconds after power is removed and the motor stops. When possible, disconnect the voltage input from the drive before adjusting the trimpots. If the trimpots must be adjusted with power applied, use insulated tools and the appropriate personal protection equipment. BE ALERT. High voltages can cause serious or fatal injury.

XP-AC series drives have four user-adjustable trimpots: maximum speed (MAX SPD), minimum speed (MIN), torque limit (TQ), and regulation under load (IR COMP).

The XP01-115AC-SL is factory calibrated for a 1/100 HP, 90 VDC motor. The XP01-115AC-E10U is calibrated for a 1/15 HP, 90 VDC motor. The XP03-115AC-SL is calibrated for a 1/4 HP, 130 VDC motor.

All adjustments increase with CW rotation, and decrease with CCW rotation. Use a non-metallic screwdriver for calibration. Each trimpot is identified on the printed circuit board.

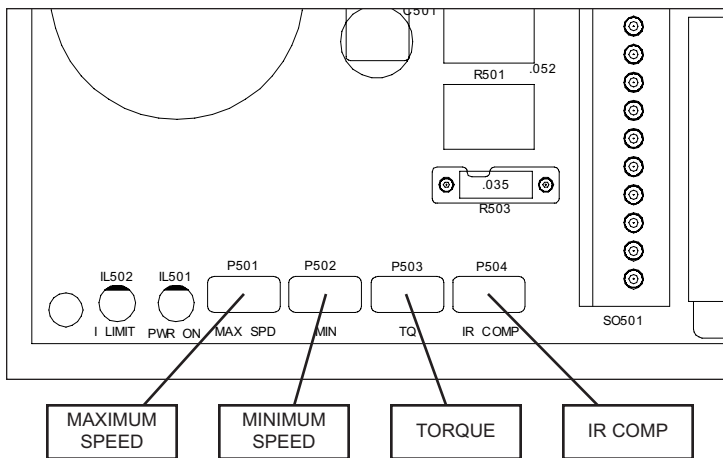

**Figure 10. XP-AC-SL Calibration Trimpot Layout**

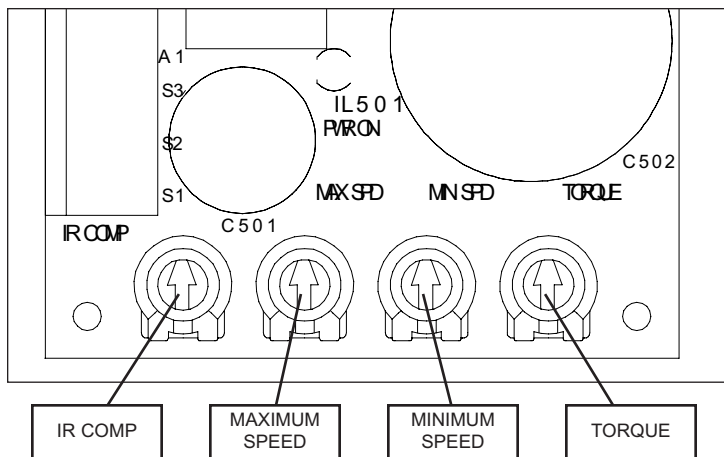

**Figure 11. XP-AC-E10U Calibration Trimpot Layout**

## **MAXIMUM SPEED (MAX SPD)**

The MAX SPD setting determines the motor speed when the speed adjust potentiometer is turned full CW. It is factory set for maximum rated speed.

To calibrate MAX SPD:

1. Set the MAX SPD trimpot full CCW.
2. Turn the speed adjust potentiometer full CW.
3. Adjust the MAX SPD trimpot until the desired maximum motor speed is reached.

## **MINIMUM SPEED (MIN)**

The MIN setting determines the motor speed when the speed adjust potentiometer is turned full CCW. It is factory set for zero speed (full CCW).

To calibrate MIN SPD:

1. Set the MIN trimpot full CCW.
2. Turn the speed adjust potentiometer full CCW.
3. Adjust the MIN trimpot until the desired minimum motor speed is reached.

## TORQUE (TQ)



### Warning

Although TORQUE can be set to 120% of motor nameplate current rating, continuous operation beyond this rating may damage the motor. If you intend to operate beyond the rating, contact your Minarik representative for assistance.

The TQ setting determines the maximum armature current output of the drive.

Recalibrate the TQ setting when using a lower current rated motor. Refer to Figure 12 on page 27 for recommended TQ settings, or recalibrate using the following procedure:









1. With the power disconnected from the drive, connect a DC ammeter (0–15 A minimum scale) in series with the armature.
2. Set the TQ trimpot to minimum (full CCW).
3. Set the speed adjust potentiometer to maximum (full CW).
4. Lock the motor armature. Be sure that the motor is firmly mounted to withstand maximum torque generated by the motor.
5. Apply line power. The motor should be stopped.
6. Slowly adjust the TQ trimpot CW until the armature current is 120% of motor rated armature current.
7. Set the speed adjust potentiometer to minimum.
8. Disconnect power from the drive.
9. Remove the ammeter in series with the motor armature if it is no longer needed and unlock the motor shaft.
10. Re-apply power to the drive.

## IR COMP

The IR COMP setting determines the degree to which motor speed is held constant as the motor load changes. It is factory set for optimum motor regulation.

Recalibrate the IR COMP setting when using a lower current rated motor. Refer to the recommended IR COMP settings in Figure 12 on page 27 or recalibrate using the following procedure:

1. Set the IR COMP trimpot to minimum (full CCW).
2. Rotate the speed adjust potentiometer until the motor runs at midspeed without load (for example, 900 RPM for an 1800 RPM motor). A hand held tachometer may be used to measure motor speed.
3. Load the motor armature to its full load armature current rating. The motor should slow down.
4. While keeping the load on the motor, rotate the IR COMP trimpot until the motor runs at the speed measured in step 2. If the motor oscillates (overcompensation), the IR COMP trimpot may be set too high (CW). Turn the IR COMP trimpot CCW to stabilize the motor.
5. Unload the motor.

XP01-115AC-SL		XP03-115AC-SL	
			
TORQUE	IR COMP	TORQUE	IR COMP
1/100 HP	90 VDC	1/15 HP	90 VDC
1750 RPM	70 mADC	1750 RPM	0.75 ADC
1/50 HP	90 VDC	1/8 HP	90 VDC
1750 RPM	1.1 ADC	1750 RPM	1.3 ADC
1/20 HP	90 VDC	1/4 HP	90 VDC
1750 RPM	0.56 ADC	1750 RPM	2.7 ADC
TORQUE	IR COMP	TORQUE	IR COMP
XP01-115AC-E10U			
			
TORQUE	IR COMP	TORQUE	IR COMP
1/20 HP	90 VDC	1/25 HP	90 VDC
1800 RPM	0.75 ADC	1800 RPM	0.47 ADC

**Figure 12 Recommended Torque and IR COMP Settings  
(actual settings may vary with each application)**

## Application Notes

### Multiple fixed speeds

Replace the speed adjust potentiometer with series resistors having a total series resistance of 10K ohms (Figure 13). Add a single pole, multi-position switch with the correct number of positions for the desired number of fixed speeds.

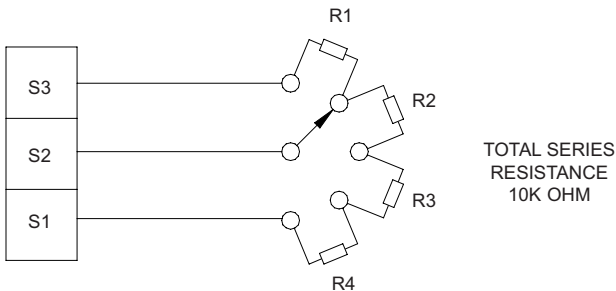

**Figure 13. Multiple Fixed Speeds**

## Adjustable speeds using potentiometers in series

Replace the speed adjust potentiometer with a single pole, multi-position switch, and two or more potentiometers in series, with a total series resistance of 10K ohms. Figure 14 shows a connection for fixed high and low speed adjust potentiometers.

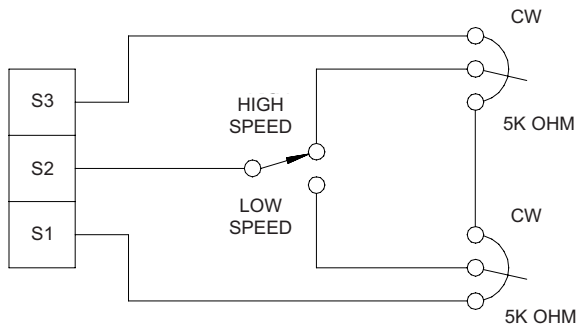

**Figure 14. Adjustable Fixed Speeds Using Potentiometers in Series**

## Independent adjustable speeds

Replace the speed adjust potentiometer with a single pole, multi-position switch, and two or more potentiometers in parallel, with a total parallel resistance of 10K ohms. Figure 15 shows the connection of two independent speed adjust potentiometers that can be mounted at two separate operating stations.

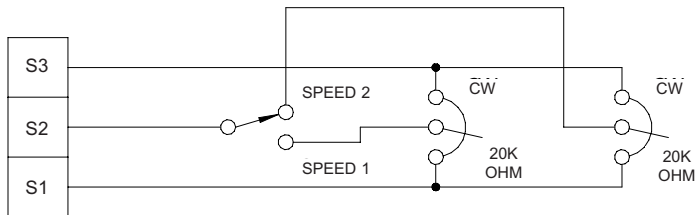

**Figure 15. Independent Adjustable Speeds**

## RUN/JOG switch

Using a RUN/JOG switch is recommended in applications where quick stopping is not needed and frequent jogging is required. Use a single pole, two position switch for the RUN/JOG switch, and a single pole, normally closed, momentary operated pushbutton for the JOG pushbutton as shown in Figure 16. When the RUN/JOG switch is set to JOG, the motor decelerates to minimum speed. Press the JOG pushbutton to jog the motor. Return the RUN/JOG switch to RUN for normal operation.

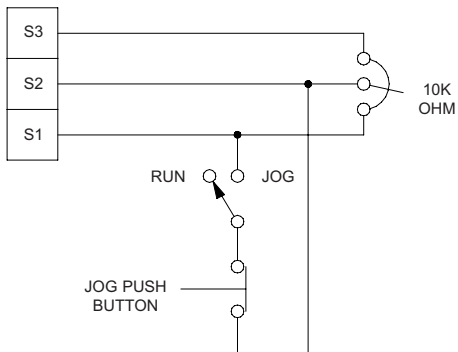

**Figure 16. RUN/JOG Switch Connection to Speed Adjust Potentiometer**

## Connection to other Minarik devices

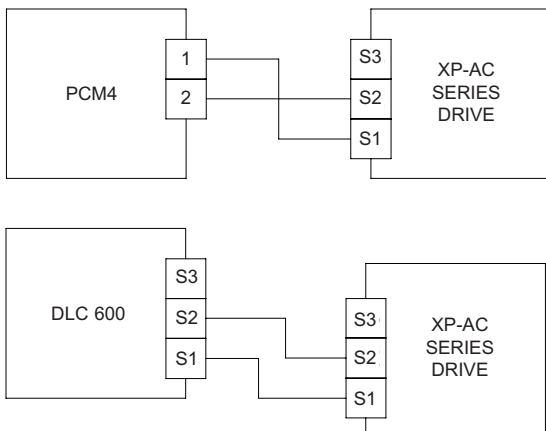

**Figure 17. Connecting an XP-AC Series Drive to a PCM4 or DLC600**

## Leader-follower application

In this application, use a PCM4 to monitor the speed of the leader motor (Figure 18). The PCM4 isolates the leader motor from the follower drive, and outputs a voltage proportional to the leader motor armature voltage. The follower drive uses this voltage reference to set the speed of the follower motor. An optional ratio potentiometer may be used to scale the PCM4 output voltage.

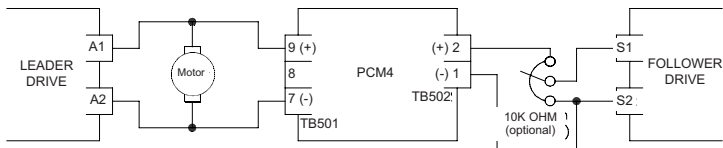

**Figure 18. Leader-Follower Application**

## Single speed potentiometer control of multiple drives

Multiple drives can be controlled with a single speed adjust potentiometer (Figure 19). Optional ratio potentiometers can be used to scale the PCM4 output voltage, allowing independent control of each drive (Figure 20, page 35).

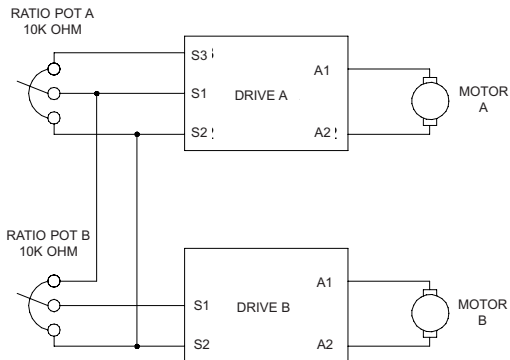

**Figure 19. Single Speed Potentiometer Control of Multiple Drives**

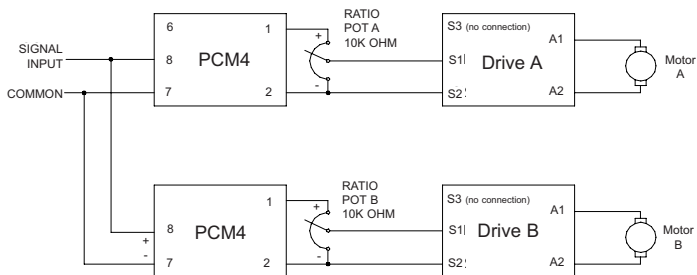

**Figure 20. PCM4 Speed Ratio Application**

## Reversing

A dynamic brake may be used when reversing the motor direction (Figure 21, page 36). Use a three pole, three position switch rated for at least the maximum DC armature voltage and maximum braking current. Wait for the motor to stop completely before switching it to either the forward or reverse direction.

### Reversing with a DIGI-LOK® controller

DIGI-LOK® controller model DLC600 can be used in a reversing application. The DLC600 must be inhibited while braking. Without the inhibit feature, the controller will continue to regulate, causing overshoot when the DIGI-LOK® is switched back to the drive.

Figure 22, page 37 shows the connection of the reversing circuit to an XP-AC Series drive and a DLC600. Note: Only one DLC option (Optical Encoder or Magnetic Pickup) may be used at a time.

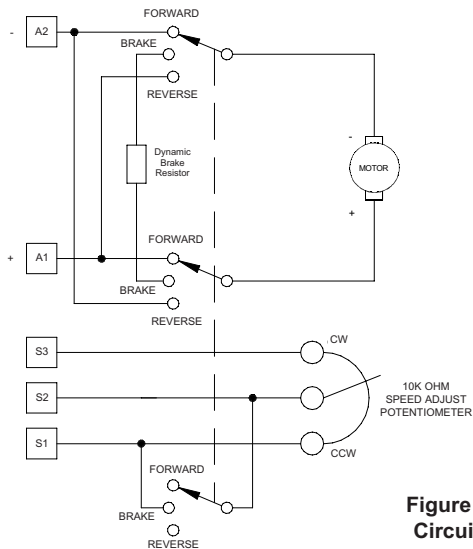

**Figure 21. Reversing  
Circuit Connections**

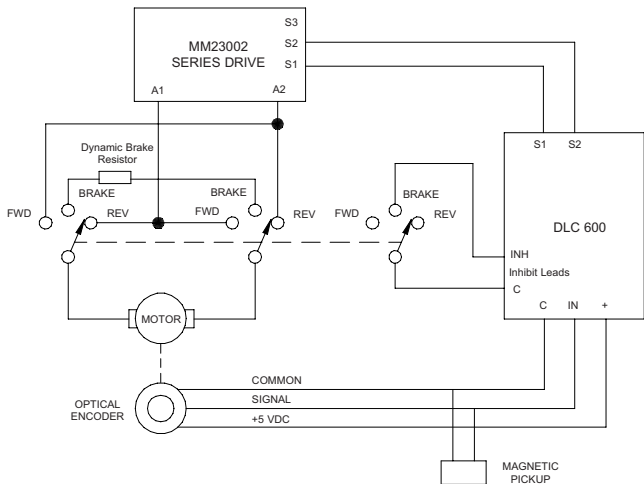
**Figure 22. Reversing with a DLC600**

---

## Troubleshooting



### Warning

Dangerous voltages exist on the drive when it is powered, and up to 30 seconds after power is removed and the motor stops. **BE ALERT.** High voltages can cause serious or fatal injury. When possible, disconnect the drive while troubleshooting. For your safety, use personal protective equipment (PPE) when operating this drive.

### Before troubleshooting

Perform the following steps before starting any procedure in this section:

1. Disconnect AC line voltage from the drive.
2. Check the drive closely for damaged components.
3. Check that no conductive or other foreign material has become lodged on the printed circuit board.
4. Verify that every connection is correct and in good condition.
5. Verify that there are no short circuits or grounded connections.
6. Check that the voltage selection switch settings match the AC line and output voltages.
7. Check that the drive's rated armature and field output is consistent with the motor rating.

For additional assistance, contact your local Minarik® distributor, or the factory direct: 1-800-MINARIK (646-2745) or Fax: 1-800-394-6334

PROBLEM	POSSIBLE CAUSE AND SOLUTION
Motor does not run	<ol style="list-style-type: none"><li>1. Check for blown fuses or tripped circuit breaker.</li><li>2. Check that the speed adjust potentiometer is securely connected to S1, S2, and S2. If an input voltage signal is used, check that the connections to S1 and S2 are secure.</li><li>3. Check that S1 and S2 are not shorted together.</li><li>4. Check that the drive receives AC power at L1 and L2.</li><li>5. Check that the motor is not jammed or restricted from movement.</li><li>6. Check that the drive is not in current limit. Recalibrate the CURRENT LIMIT (TORQUE) trimpot if it is set too low (see page 27 for recommended trimpot settings).</li></ol>
Fuse blows or circuit breaker trips	<ol style="list-style-type: none"><li>1. Check all wiring for shorts, grounds, or misconnections.</li><li>2. Check that the drive is configured to match the motor rating.</li><li>3. Check that the motor is not jammed or restricted from movement.</li><li>4. Check that the fuse size is correct for the motor being driven.</li></ol>

PROBLEM	POSSIBLE CAUSE AND SOLUTION
Motor runs too fast at the maximum speed setting	1. Check that the MAX SPD setting is not set too high.
Motor runs in the wrong direction	1. Remove AC line voltage. 2. Reverse connection to the motor armature.
Motor slows or is unstable under load	1. Check that the drive has been correctly calibrated for the motor. 2. Check that the motor is not overloaded. 3. Readjust the IR COMP slightly CW until motor runs at proper speed.
Motor runs at full speed at all times	1. Check that S2 and S3 are not shorted together.

## Block Diagrams

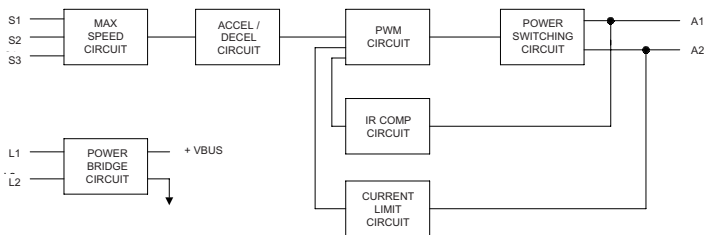

**Figure 23. XP-AC Series Block Diagram**

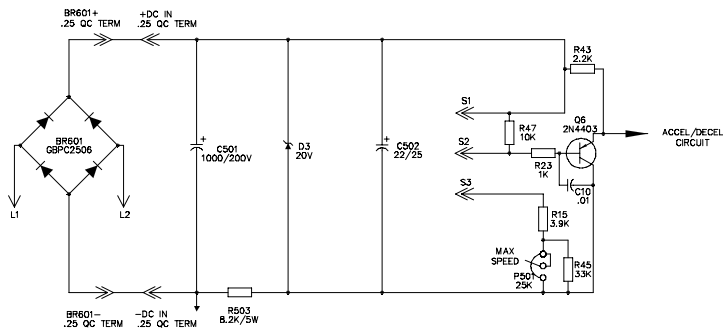

Figure 24. XP-AC Series Input Circuit Diagram

## Replacement Parts

Replacement parts are available from Minarik Corporation and its distributors for this drive series.

Table 4. Replacement Parts

Model No.	Symbol	Description	Minarik® P/N
XP01-115AC-E10U	C503	100 mF, 25VDC Radial	011-0079
	D501	16 A, 300 V Diode	071-0054
	Q501	Power MOSFET	070-0043
	R501	6.8K W 10W Resistor	032-0103
		10 KW Potentiometer Kit	202-0003
XP01-115AC-SL	C503	220 MFD 200V High Ripple	011-0069
	D501	Isolated, 16 AMP, 300 V	071-0050
	Q501	Power MOSFET	070-0043
	R501	1.5W, 5W Resistor	032-0161
	R502	3.9KW, 5 W Resistor	032-0149
	FU501	2A, 3AG Fast-Acting Fuse	050-0030
		10 KW Potentiometer Kit	202-0003
XP03-115AC-SL	C503	220 MFD 200 V High Ripple	011-0069
	D501	16 A, 300 V Diode	071-0054
	Q501	IRF640 Power MOSFET	070-0043
	R502	3.9KW, 5 W Resistor	032-0149
	BR501	25 A, 800 V Diode Bridge	073-0006
	FU501	4A, 3AG Fast-Acting Fuse	050-0028
		10 KW Potentiometer Kit	202-0003

## **Unconditional Warranty**

### **A. Warranty**

Minarik Corporation (referred to as "the Corporation") warrants that its products will be free from defects in workmanship and material for twelve (12) months or 3,000 hours, whichever comes first, from date of manufacture thereof. Within this warranty period, the Corporation will repair or replace, at its sole discretion, such products that are returned to Minarik Corporation, 901 East Thompson Avenue, Glendale, CA 91201-2011 USA.

This warranty applies only to standard catalog products, and does not apply to specials. Any returns for special controls will be evaluated on a case-by-case basis. The Corporation is not responsible for removal, installation, or any other incidental expenses incurred in shipping the product to and from the repair point.

### **B. Disclaimer**

The provisions of Paragraph A are the Corporation's sole obligation and exclude all other warranties of merchantability for use, express or implied. The Corporation further disclaims any responsibility whatsoever to the customer or to any other person for injury to the person or damage or loss of property of value caused by any product that has been subject to misuse, negligence, or accident, or misapplied or modified by unauthorized persons or improperly installed.

### **C. Limitations of Liability**

In the event of any claim for breach of any of the Corporation's obligations, whether express or implied, and particularly of any other claim or breach of warranty contained in Paragraph A, or of any other warranties, express or implied, or claim of liability that might, despite Paragraph B, be decided against the Corporation by lawful authority, the Corporation shall under no circumstances be liable for any consequential damages, losses, or expense arising in connection with the use of, or inability to use, the Corporation's product for any purpose whatsoever.

An adjustment made under warranty does not void the warranty, nor does it imply an extension of the original 12-month warranty period. Products serviced and/or parts replaced on a no-charge basis during the warranty period carry the unexpired portion of the original warranty only.

If for any reason any of the foregoing provisions shall be ineffective, the Corporation's liability for damages arising out of its manufacture or sale of equipment, or use thereof, whether such liability is based on warranty, contract, negligence, strict liability in tort, or otherwise, shall not in any event exceed the full purchase price of such equipment.

Any action against the Corporation based upon any liability or obligation arising hereunder or under any law applicable to the sale of equipment or the use thereof, must be commenced within one year after the cause of such action arises.

